



Eveready Battery Company, Inc.

Checkerboard Square
St. Louis, MO 63164
Telephone 1-800-383-7323
Internet: www.energizer.com

Engineering Data

ENERGIZER NO. EPX30

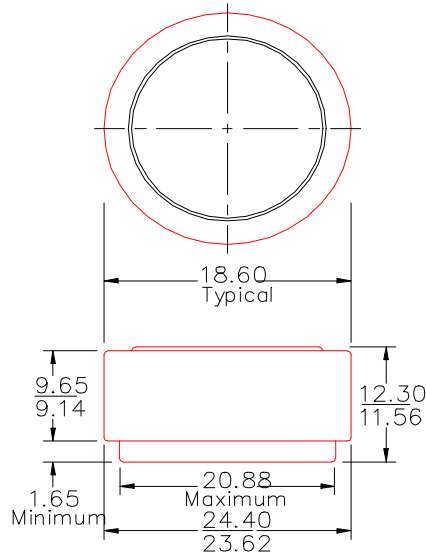

Chemical System: Manganese Dioxide (MnO₂)
Designation: ANSI / NEDA-1202AP, IEC-2LR53
Typical Capacity (to 1.8V): 160 mAh
(Rated capacity at 600 ohms @ 21°C)
Typical Weight: 14 grams (0.5 oz.)
Volume: 5.4 cubic centimeters (0.33 cubic in.)
Cells: Two 1522 in series
Terminals: Flat Contact

Dimensions (mm)

Millimeters	Inches
1.65	0.065
9.14	0.360
9.65	0.380
11.56	0.455
12.30	0.484
18.60	0.732
20.86	0.821
23.62	0.930
24.40	0.961

IMPORTANT NOTICE

This data sheet contains information specific to batteries manufactured at time of its publication. Please contact your Energizer representative for most current information. Contents herein do not constitute a warranty.