



Eveready Battery Company, Inc.

Checkerboard Square
St. Louis, MO 63164
Telephone 1-800-383-7323
Internet: www.energizer.com

Engineering Data

ENERGIZER NO. E675E

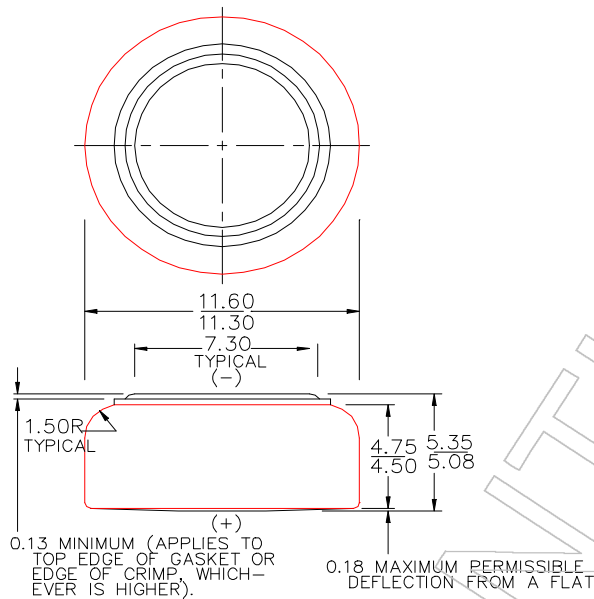

Chemical System: Mercuric Oxide (Zn/HgO)
Designation: ANSI / NEDA-1127M, IEC-NR44
Average Service Capacity (to 0.9 volts): 200 mAh
 (Rated Capacity at 625 ohms @ 21°C)
Typical Weight: 42.6 grams (0.09 oz.)
Volume: 0.5 cubic centimeters (0.03 cubic in.)
Terminals: Flat Contact

Dimensions (mm)

Millimeters	Inches
0.13	0.005
0.18	0.007
1.50	0.059
4.50	0.177
4.75	0.187
5.08	0.200
5.35	0.211
7.30	0.287
11.30	0.445
11.60	0.457

IMPORTANT NOTICE

This data sheet contains information specific to batteries manufactured at time of its publication. Please contact your Energizer representative for most current information. Contents herein do not constitute a warranty.